

REV	DESCRIPTION	ECN #	CHG BY	DATE	APP'D
A	CONVERTED TO 3D	10664	TAS	03/10/17	EZR

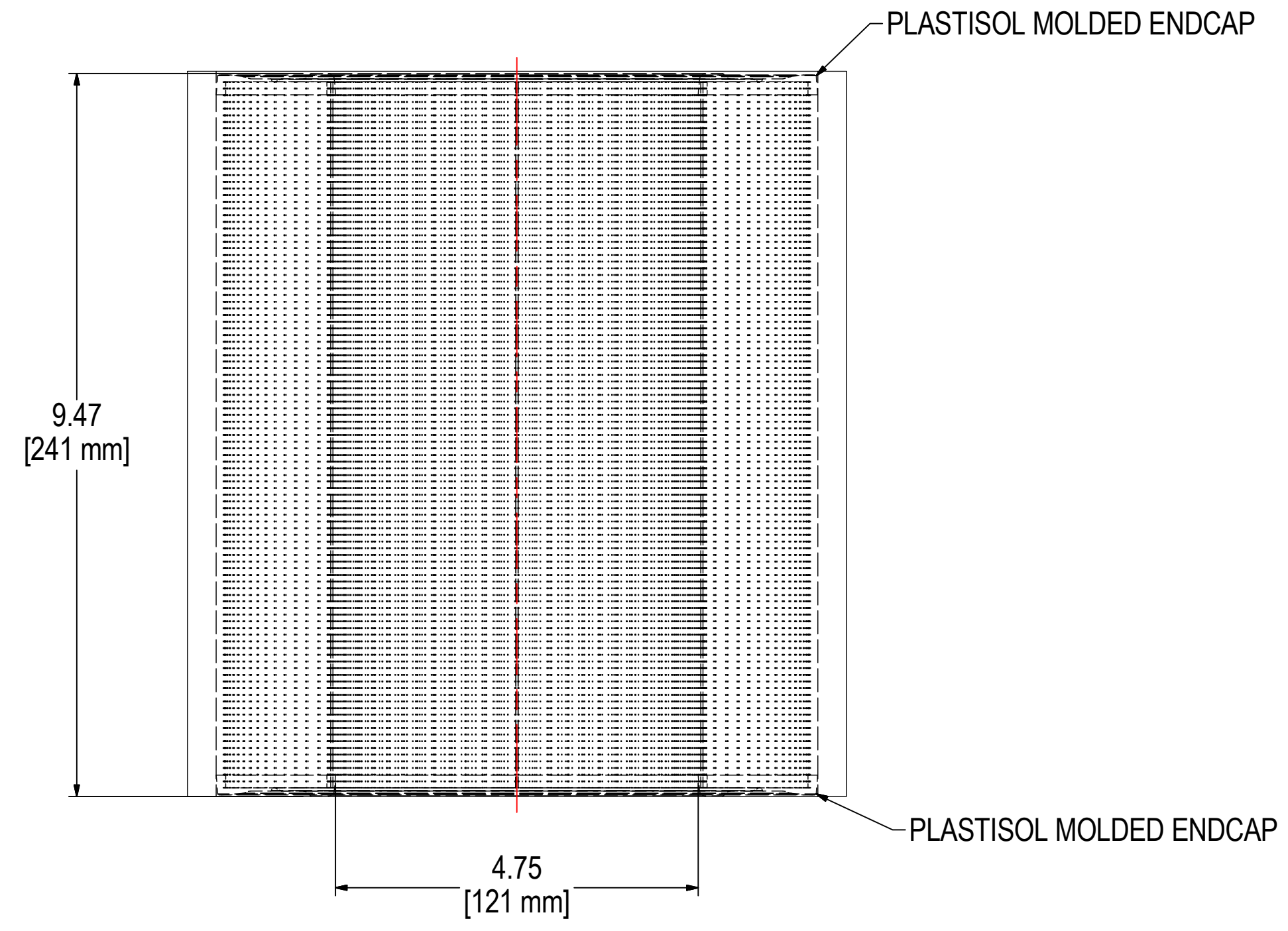
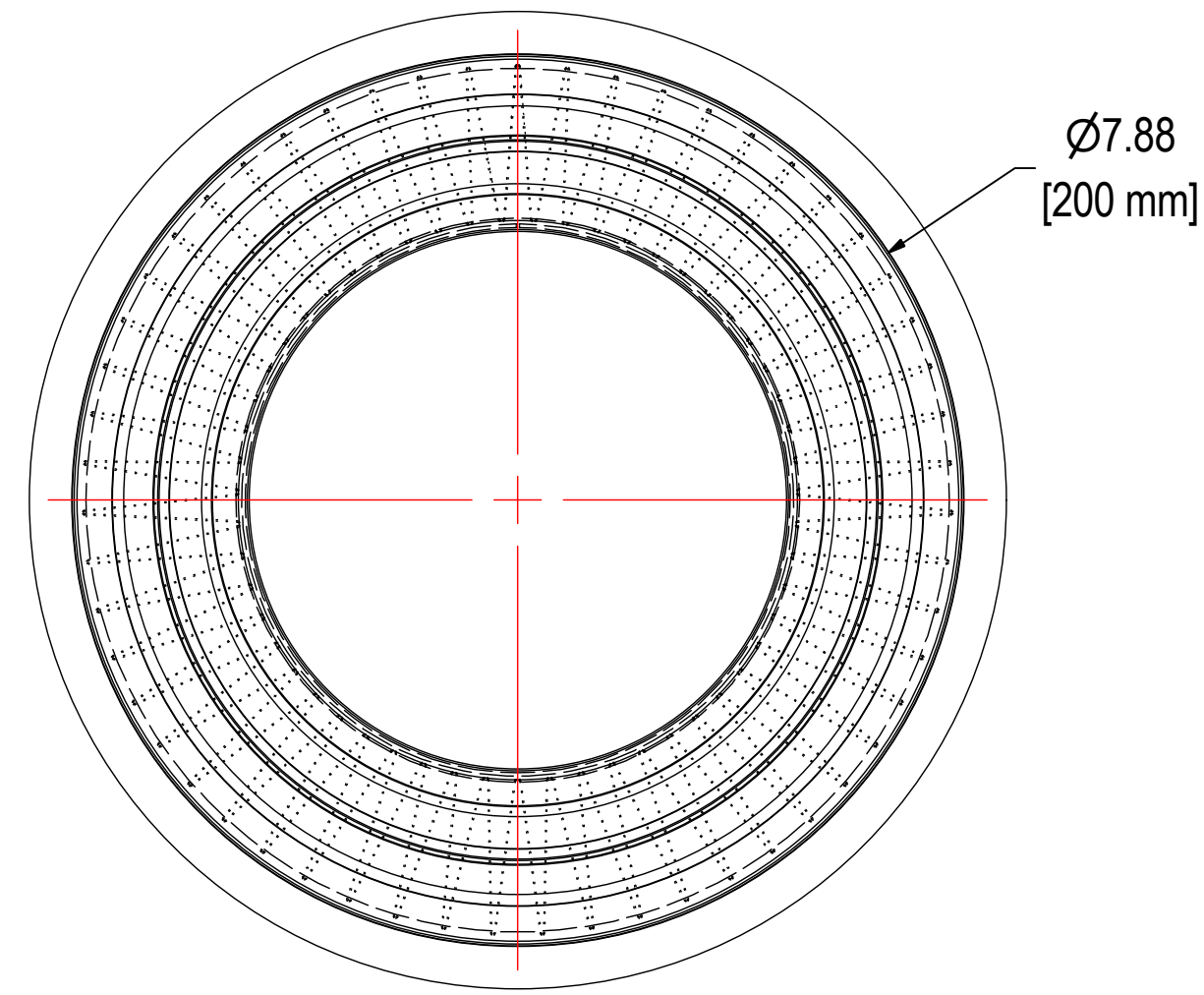

ELEMENT SPECS	
PART NUMBER	235P
MATERIAL	Polyester
FLOW RATE	570 CFM 968 m ³ /hr
SURFACE AREA	8.3 ft ² 0.8 m ²
I.D.	SEE DRAWING
O.D.	SEE DRAWING
HEIGHT	SEE DRAWING

SOLBERG
Filtration • Separation • Silencing
630.773.1363 • www.solbergmfg.com

THE INFORMATION CONTAINED HEREIN IS CONFIDENTIAL AND THE PROPERTY OF SOLBERG MANUFACTURING INC. AND IT IS FURNISHED TO YOU WITH THE EXPRESS UNDERSTANDING THAT IT WILL NOT BE REPRODUCED, COPIED IN ANY MANNER, LOANED OR OTHERWISE TRANSFERRED TO OTHERS ENTIRELY OR IN PART, NOR USED FOR ANY PURPOSE OTHER THAN FOR WHICH IT WAS FURNISHED. IT WILL BE RETURNED UPON REQUEST TO SOLBERG MANUFACTURING INC. THE ABOVE RESTRICTION IS IN ADDITION TO, AND DOES NOT IN ANY WAY ALTER, ANY OTHER RESTRICTIONS WHICH MAY APPLY TO THE INFORMATION CONTAINED HEREIN.

TOLERANCES
DIMENSIONS ARE FOR REFERENCE ONLY. ALL DIMENSIONS ARE SUBJECT TO CHANGE UPON PRODUCTION.
UNLESS OTHERWISE SPECIFIED:
-DIMENSIONS ARE IN INCHES
-REF: APPROXIMATE DIMENSIONS, NO TOLERANCES APPLY
-FINISH: BREAK EDGES TO .005-.020 RADIUS/CHAMFER

MODEL NUMBER: 235P	SHEET: 1 OF 1
DESCRIPTION: 235P, POLY	
PROJECT: SD16081	DRAWN BY: CRW
DATE: 9/24/2010	APPROVED BY: P.G.
	DATE: 9/24/2010
	REV: A